

LITHEA

le forme sensibili della pietra



Index

Designers	2
Rivestimenti / 3D Wall Tiles	3
Petra S M L XL	4,5
Decoro Geologico	6,7
Trame	8,9
Bolle	10,11
Petali	12,13
Dune	14,15
Curve	16,17
Lavabi / Basins	18
Ciuri	19
Unna a self standing	20
Unna b self standing	21
Unna a vanity	22
Unna b vanity	23
Naca	24
Dune self standing	25
Dune vanity	26
Petali vanity	27
Ciottolo 60/40 a	28
Ciottolo 60/40 b	29
Curve vanity	30
Complementi / Objects	31
La Torre dei trampolini	32

LITHEA “le forme sensibili della pietra” è un brand di interior design made in italy fondato nel 2008, da Patrizia Furnari, in collaborazione con la MGM FURNARI storica azienda italiana con mezzo secolo di esperienza nella lavorazione dei materiali lapidei.

LITHEA è un'azienda che persegue l'intento di coltivare la sperimentazione e di incentivare l'artigianato italiano pur seguendo le logiche di serie nella produzione e nella distribuzione dei suoi prodotti in tutto il mondo.

La scelta di misurarsi con il design, legando il proprio nome a designer di fama internazionale, per apportare al settore dei materiali litici eccezionali cambiamenti in termini di progettazione, innovazione tecnologica, produzione e finitura, è la nuova e suggestiva regola su cui LITHEA ha impostato i futuri percorsi professionali e produttivi.

Le tecnologie produttive, in particolare, ricorrono a lavorazioni a controllo numerico dei blocchi di materiale e, ai processi computerizzati segue la rielaborazione dei prodotti affidata al talento manuale di artigiani specializzati.

LITHEA reinventa il volto della materia litica facendola entrare a pieno titolo tra i materiali della contemporaneità. La pietra rivela forme sensibili dando vita a pelli comunicative in continua trasformazione ed a elementi di arredo dalla forte personalità e caratteristiche di assoluta unicità.

“Il marmo diventa leggero, quasi trasparente, da sfiorare, toccare, usare. Da riempire con acqua, essenze, luce”.

LITHEA “sensitive forms of stone” is a brand of interior design made in Italy was founded in 2008 by Patrizia Furnari, in collaboration with MGM FURNARI historic Italian company with half a century of experience in the processing of stone materials.

LITHEA is a company which cultivates experimentation and encourages Italian craftsmanship, while following the logic of series in its production and distribution of its products worldwide.

Production Technology, especially, makes use of the numerical control of the block of material processed and employs computerized systems for the first stages of manufacture, the stone being hand crafted by specialist stone masons only once this initial treatment has been carried out.

The decision to compete with the design, linking its name to internationally renowned designers, to bring to the field of stone materials exceptional changes in terms of design, technological innovation, production and finishing, is the new and impressive rule on which LITHEA has set the future professional and productive route.

LITHEA reinvents the face of the stone material allowing it to enter fully between the materials of contemporaneity. The stone reveals sensitive forms giving life to communicative skins in continuous transformation and to elements of furniture by the strong personality and characteristics of absolute uniqueness.

“The marble becomes light, almost clear, to touch, caress, use. To fill with water, essence, light. “

<p>LITHEA PRODUCTS</p>
<p>LITHEA 3D WALL TILE</p>
<p>LITHEA COLLEZIONE LAVABI</p>
<p>LITHEA BASINS COLLECTION</p>

Lastre di pietra naturale sulle quali vengono praticate delle incisioni mediante l'azione di macchinari ad alta precisione. Ideali per il rivestimento di pareti interne ed esterne, acquisiscono, grazie all'effetto di luci ed ombre, un inedito ed elegante valore decorativo suscitando intense sensazioni emozionali.

Slabs of stone on which are practiced of engravings by action of machinery with high precision. Ideal for the coating of internal and external walls, acquire, thanks to effect of light and shadows, a new and elegant decorative value provoking intense emotional sensations.

LITHEA COLLEZIONE LAVABI
Nel blocco di materia solida si apre un vuoto e la pietra prende forma per accogliere l'acqua. Forme pure, dure, geometriche, spigolose, levigate, curvilinee, sinuose, organiche. Forme lineari mai invasive, prive di inutili estetismi per puntare alla vera eleganza.

LITHEA BASINS COLLECTION
In the block of solid opens an empty and the stone takes shape to accept water. forms as well, hard, geometric, pointed, smooth, curvilinee, sinuous, organic. Linear forms never invasive without unnecessary aesthetics to point to real elegance.



Michele De Lucchi Nato a Ferrara nel 1951, si è laureato in architettura a Firenze. E' stato tra i protagonisti di Alchymia e Memphis. E' stato responsabile del Design Olivetti dal 1992 al 2002 ed ha sviluppato progetti sperimentali per Compaq, Philips, Vitra. Ha ristrutturato edifici in Giappone, in Germania e in Italia per Enel, Olivetti, Piaggio, Poste Italiane, Telecom Italia. Dal 1999 al 2005 ha riqualficato alcune Centrali elettriche di Enel. Per Poste Italiane, Telecom Italia, Hera, Intesa Sanpaolo e altri Istituti italiani ed esteri ha collaborato all'evoluzione dell'immagine. Nel 1990 ha creato Produzione Privata, una piccola impresa che realizza prodotti impiegando tecniche artigianali. Una selezione dei suoi oggetti è esposta nei più importanti musei d'Europa, degli Stati Uniti e del Giappone. Nel 2000 è insignito della onorificenza di Ufficiale della Repubblica Italiana. Nel 2001 è nominato Professore Ordinario per chiara fama presso l'Istituto UniversitariodiArchitetturaa Venezia. Dal2008èProfessoreOrdinariopressolaFacoltàdelDesignalPolitecnico diMilano.

Michele De Lucchi was born in 1951 in Ferrara and graduated in architecture in Florence. He was a prominent figure in movements like Alchymia and Memphis. For Olivetti he has been Director of Design from 1992 to 2002 and he has developed experimental projects for Compaq Computers, Philips, Siemens and Vitra. His architectural designs have been mainly for office buildings in Japan, in Germany and in Italy for Enel, Olivetti, Piaggio, Poste Italiane, Telecom Italia. From 1999 to 2005 he has been appointed to renovate some of ENEL's (the Italian Electricity Company) power plants. For Poste Italiane, Telecom Italia, Hera, Intesa Sanpaolo and at other Italian and foreign banks he has collaborated to the evolution of the corporate image. In 1990 he fonde Produzione Privata a small scale company where products are realized using artisan techniques and crafts. Selections of his products are exhibited in the most important design Museums in Europe, United States and Japan. In 2000 he was appointed Officer of Italian Republic. In 2001 he has been nominated Professor at the Design and Art Faculty at the University in Venice. From 2008 he is Professor at the Design Faculty of the Politecnico of Milan.

<p>LITHEA PRODUCTS</p>
<p>LITHEA 3D WALL TILE</p>
<p>LITHEA COLLEZIONE LAVABI</p>
<p>LITHEA BASINS COLLECTION</p>

Marco Piva definisce il suo linguaggio emozionante, fluido e funzionale, firmando le proprie realizzazioni legate all'architettura, al product e all'interior design. Lo sforzo nella ricerca materica e tecnologica, il valore della differenziazione, l'innovazione progettuale sfociano nella fondazione dello Studiodada Associati, la cui produzione diventa una delle più rappresentative del periodo del Radical Design. Negli anni '80 apre lo Studio Marco Piva, la cui attività spazia dai grandi progetti architettonici alla progettazione d'interni, fino al disegno industriale. Viaggiatore prima ancora che progettista, studia e crea soluzioni progettuali intrise di libertà stilistica, gli oggetti si caricano di emozionalità e nuova simbologia, i colori contrastano ogni intellettualismo e rigidità.Ha realizzato numerosi progetti di architettura e interior design.In Giappone, a Osaka, ha partecipato alla progettazione e costruzione dell'innovativo complesso residenziale Next 21, ha realizzato il Laguna Palace a Mestre, il Port Palace a Montecarlo, l'Hotel Mirage a Kazan, l'Una Hotel di Bologna, il T Hotel di Cagliari. Per il Gruppo Boscolo realizza le Suites dell'Exedra di Roma, il B4 Net Tower di Padova ed il Tower Hotel di Bologna. A Dubai, su Palm Jumeirah, ha progettato il Tiara Hotel e l'Oceana Hotel. Sempre a Dubai ha progettato l'innovativo complesso Porto Dubai. In Russia sta progettando il nuovo complesso del Porto fluviale di Novosibirsk. In Italia è attualmente impegnato nella progettazione dell'Alemagna Uno a Mogliano Veneto, oltre che nella realizzazione del complesso multifunzionale Le Terrazze di Treviso.Esporta all'estero il suo know how ed è uno dei pochi progettisti italiani che negli Emirati riesce ancora a costruire, infatti, è impegnato nella realizzazione del complesso residenziale Rawdhat Residential Buildings ad Abu Dhabi. Intanto in Italia sta portando avanti il progetto architettonico di ristrutturazione ed ampliamento dell'Hotel Gallia a Milano che terminerà nel 2012.Marco Piva Atelier Design disegna per: Arflex, Altreforme, Arpa Industriale, Bross, Cabas, Casa Più, De Castelli, Deko, Ege, Gervasoni, i Guzzini Illuminazione, Iradium, Jacuzzi, La Murrina, Lamm, Leucos, Meritalia, Moroso, Novello, Pedrali, Pierantonio Bonacina, Potocco, Rapsel, Reflex, Schonhuber Franchi, Sicis, Stella Rubinetterie, Tre P Tre Più, Unopiù, Valpra, Vda, Zonca.

Exciting, fluid, functional. This is the language that distinguishes Marco Piva’s architectural creations, product design and interior design. A traveller and a designer, an innovator who is educated in rational approaches, he studies and creates design solutions which are pervaded by stylistic freedom and compositional sobriety.New design interpretation perspectives have originated from his academic training. The Faculty of Architecture of Milan guided disputes and challenges during the 1970s with initiatives aimed at rejecting construction archetypes and the deconstruction of obsolete dogmas. He received his degree from the Politecnico di Milano in 1977, which provided him with a starting point for a career that has been devoted to the development of a functional method of use, original in its syntax, a creator of visible and authentic situations in both national and international settings.Efforts that focused on the search for materials and technology, the value of differentiation and design innovation led to the founding of Studiodada Associati, with creations that became some of the most symbolic representations of the Radical Design period. The objects are full of emotion and new symbolism, colours contrast intellectualism and rigidity.Journeys result in influences: technologies amplify the expressive and functional abilities of both architecture and design. Wonder and research are transferred from micro-contexts to a scale of macro-projects. The design horizon expands its reach, interacting with elements of extraordinary complexity. The construction of such a specific know-how is put to the service of a new and completely personal project.In 1984 Studio Marco Piva was opened, with activities ranging from large architectural projects for tourist facilities, to interior design and finally industrial design for the production of accessories for common areas. Creativity interacts with the definition of spaces, the movements of sense and scale, the transgression of visual codes, aiming at that element of surprise that is able to lead the user to an unusual place, which remains magical and surprising.Incessant experimentation focusing on the use of materials and technologies, a predilection for contrasting combinations of materials with harmonious effects, the extension of specific materials to unconventional contexts and the reinterpretation of traditional manufacturing techniques to create innovative procedures elevate the in-depth examination of industrial design to never-before-seen levels, which were acknowledged from 1987 to 1990 with an appointment as a member of the Presidential Board of ADI, the Industrial Design Association.In 2002, “Atelier Design” was established, the Studio’s atelier which was created as a centre for industrial design research and development, placing its experience at the service of leading companies in the fields of seating, furnishing, plumbing and bathroom fixtures, lighting and laminate print manufacturing.

<p>LITHEA PRODUCTS</p>
<p>LITHEA 3D WALL TILE</p>
<p>LITHEA COLLEZIONE LAVABI</p>
<p>LITHEA BASINS COLLECTION</p>

Fabio Fazio Nato a Neuchatel nel 1974, si è laureato in Architettura a Reggio Calabria. E' responsabile del Design della Lithea dalla nascita dell'azienda, per la quale cura anche l'immagine. Si occupa di: progettazione di oggetti e elementi di arredo di taglio artigianale e industriale, progettazione di nuovi edifici, ristrutturazione di edifici privati e progettazione di spazi pubblici in Sicilia. E' stato docente di Progettazione artistica di impresa della Rome University of Fine Arts – Libera Accademia di belle Arti di Roma.

Fabio Fazio was born in 1974 in Neuchatel and graduated in architecture in Reggio Calabria. He is the Design Director of Lithea company, for which also takes care of the image. He deals with: the design of objects and furniture of handicraft and industrial, design of new buildings, restructuring of private buildings and planning of Public spaces in Sicily. He has been professor of artistic design at the Rome University of Fine Arts - Libera Accademia di Belle Arti in Rome.



Designers



Rivestimenti

3D Wall Tiles

Petra S M L XL





Materiali / Material

Bianco Fenice, Grigio Tunisi, Grigio Billiemi, Bianco di Carrara,
Marmo Nero, Rosso Ducale, Rosso San Marco.

Dimensioni / Dimensions

S 300x300x20 mm - M 450x450x20 mm - L 900x600x20 mm - XL 900x900x20 mm

Peso / Weight

S 3,6 kg - M 8,2 kg - L 21,9 kg - XL 32,8 kg

Design

Marco Piva

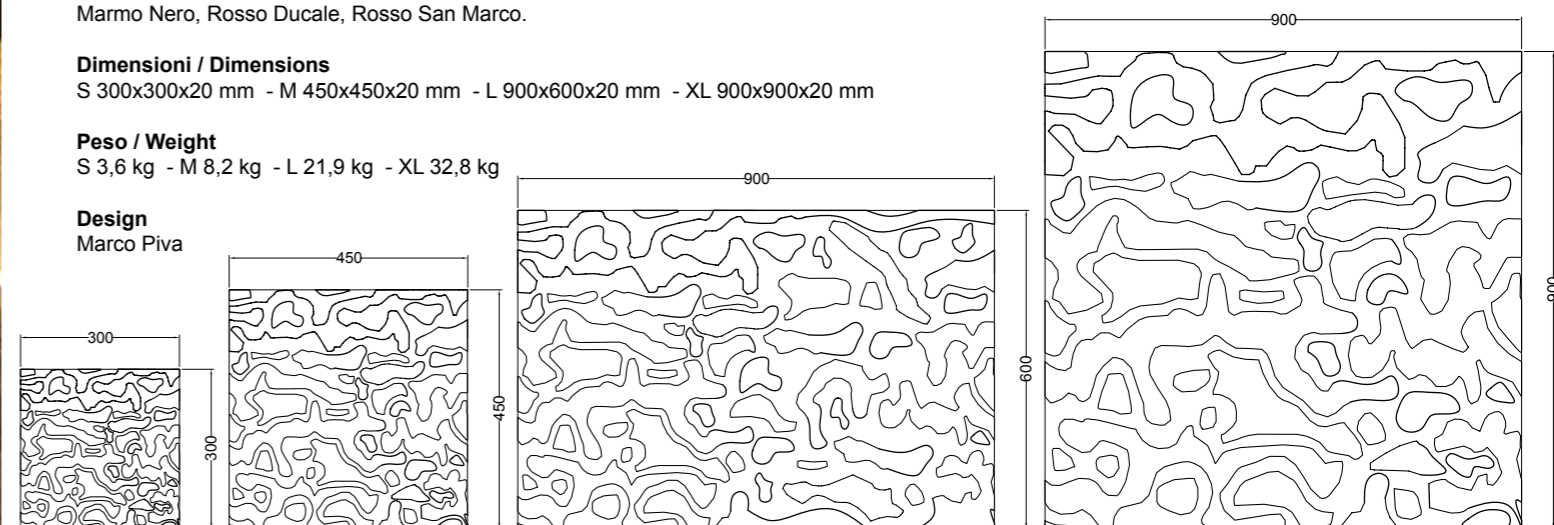

Petra S M L XL

Decoro geologico





Materiali / Material
 Pietra Lavica dell'Etna.

Dimensioni / Dimensions
 A 580x340x20 mm - Ar 580x340x20 mm - B 419x179x20 mm
 Br 419x179x20 mm - C 580x340x20 mm - Cr 580x340x20 mm

Peso / Weight
 A 8,2 kg - Ar 8,2 kg - B 3,8 kg - Br 3,8 kg - C 8,2 kg - Cr 8,2 kg

Design
 Michele De Lucchi

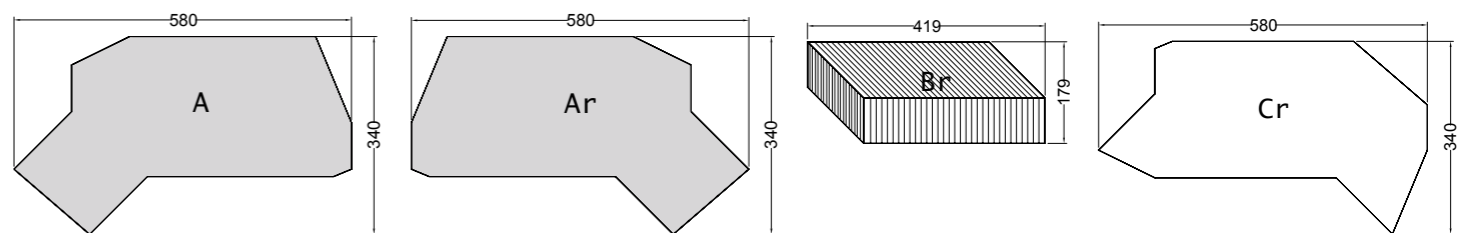
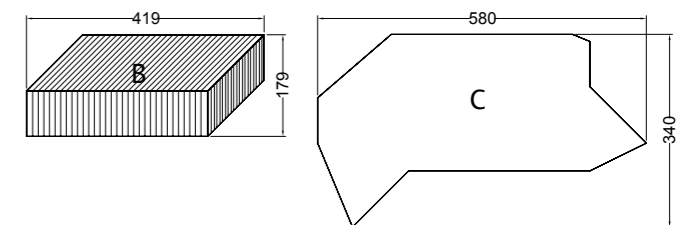

Decoro Geologico



Trame

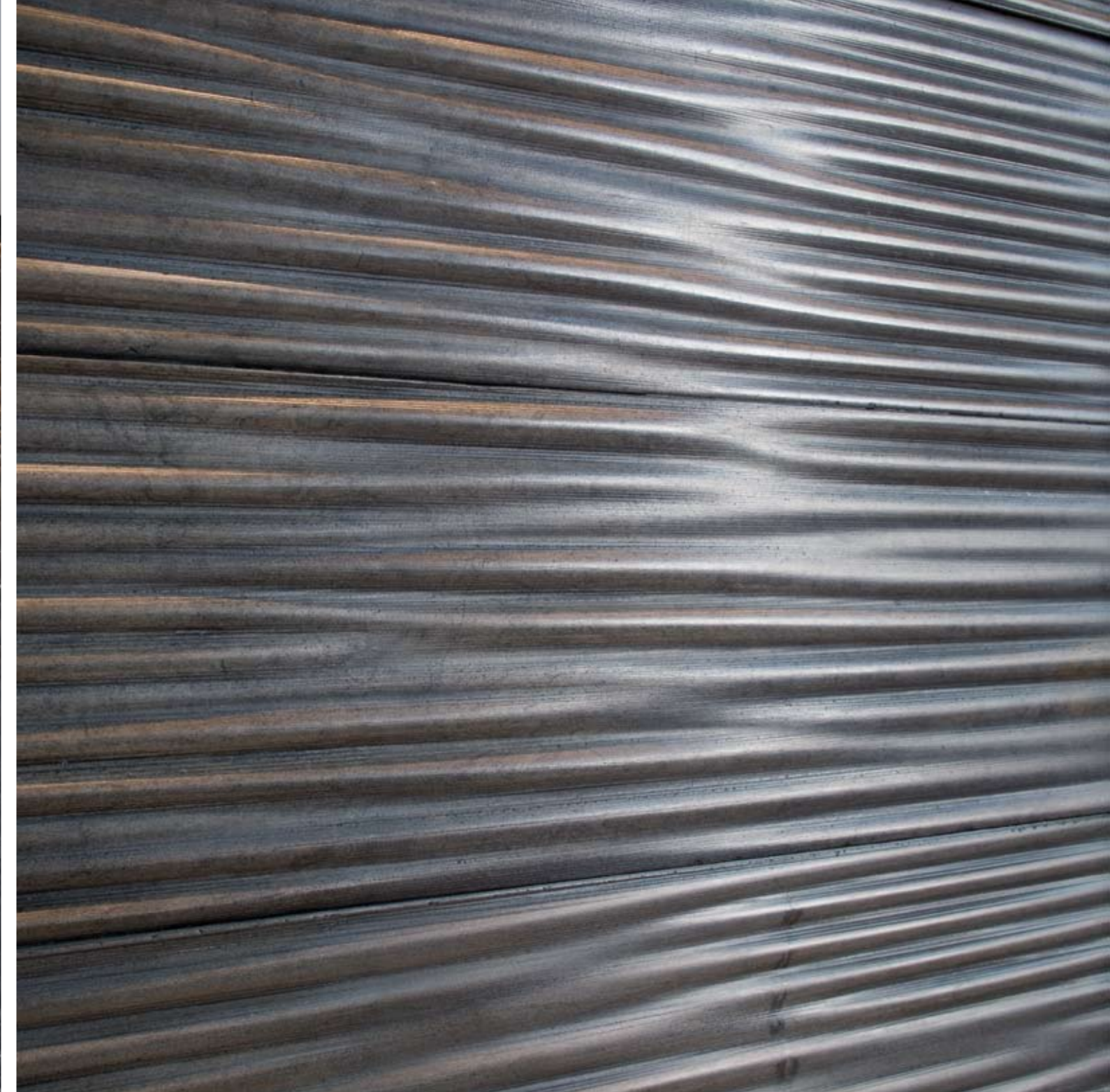

Materiali / Material

Bianco Fenice, Grigio Tunisi, Grigio Billiemi, Bianco di Carrara,
Marmo Nero, Rosso Ducale.

Dimensioni / Dimensions

600x150x20 mm

Peso / Weight

3,6 kg

Design

Fabio Fazio

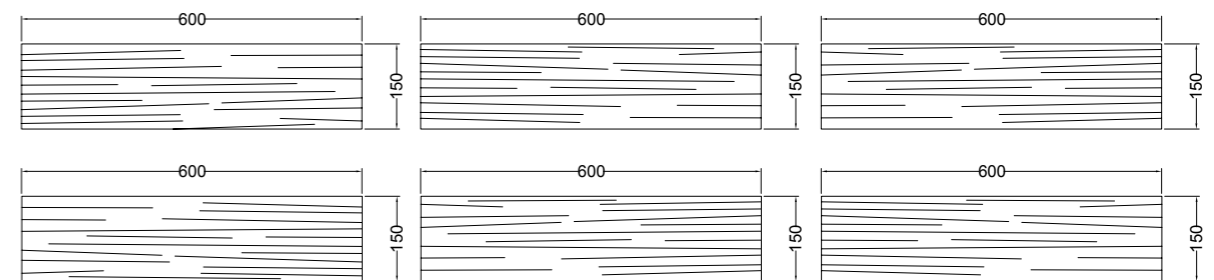

Trame

Bolle





Materiali / Material

Bianco Fenice, Grigio Tunisi, Grigio Billiemi, Bianco di Carrara, Marmo Nero, Rosso Ducale.

Dimensioni / Dimensions

600x600x20 mm

Peso / Weight

14,6 kg

Design

Fabio Fazio

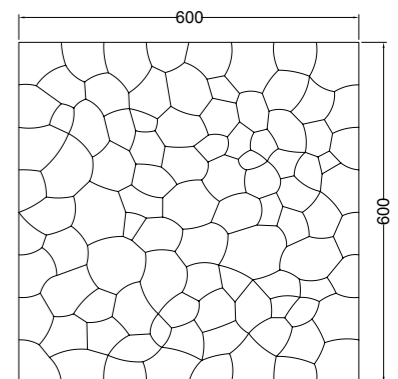

Petali



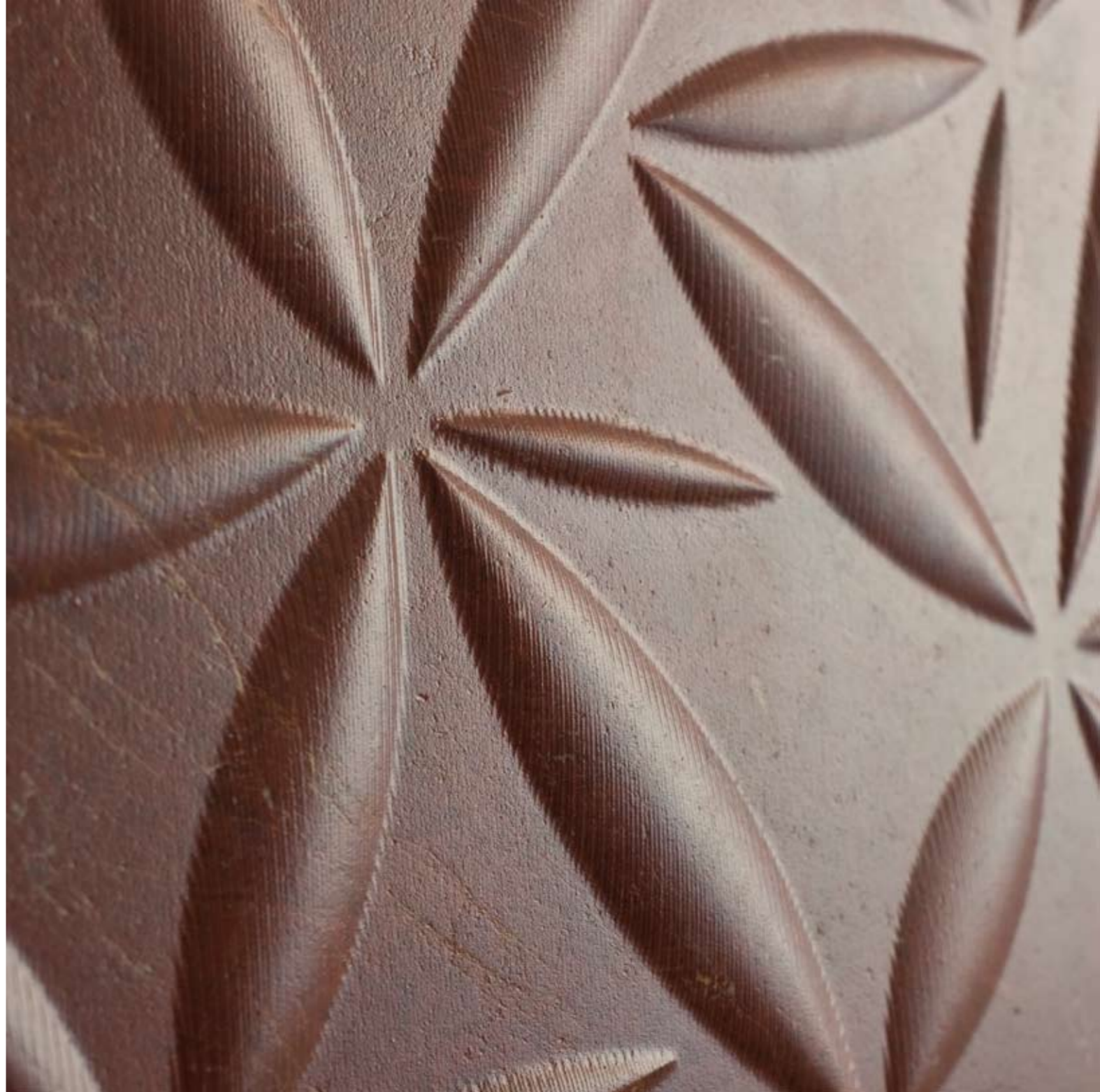
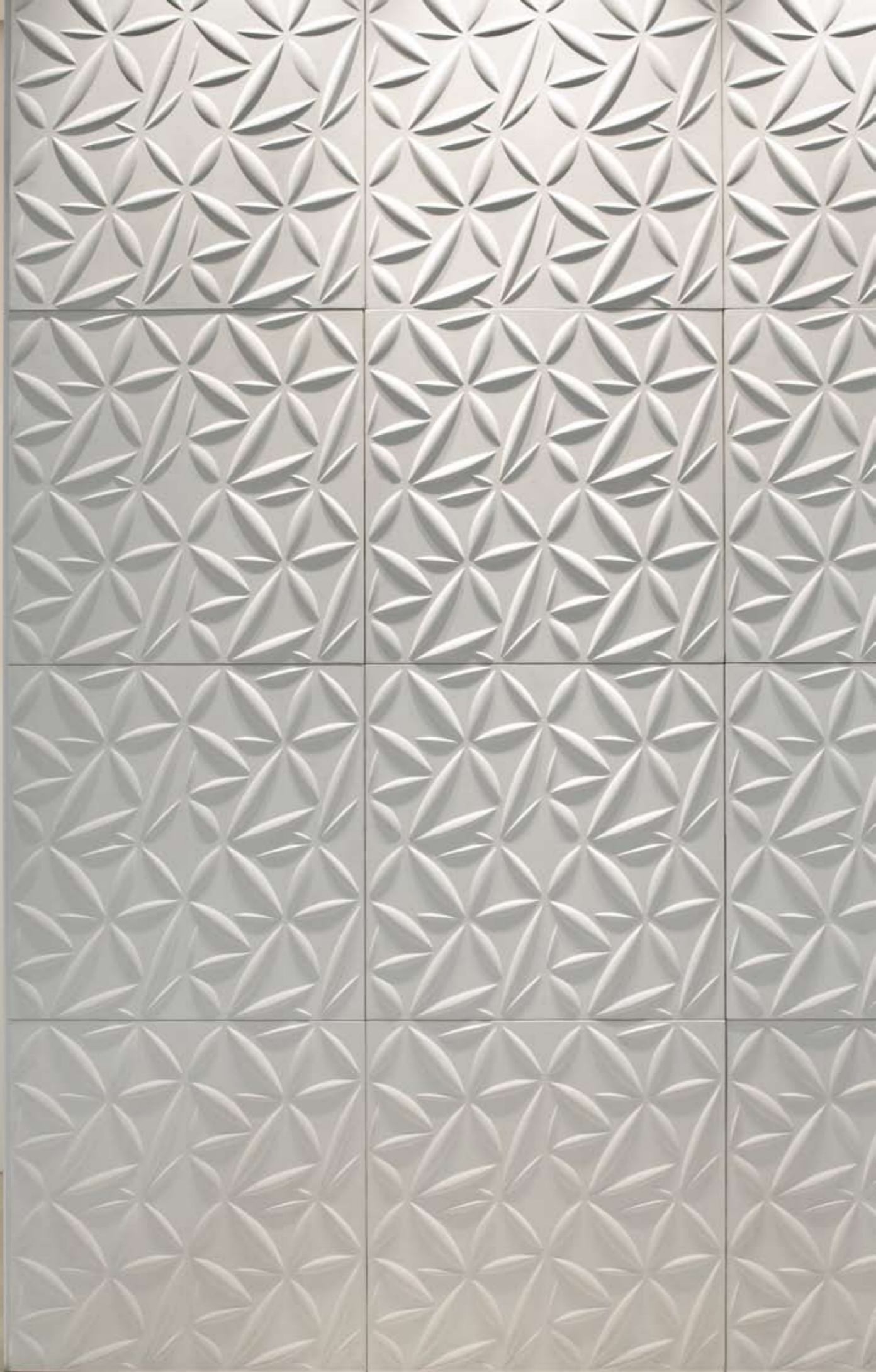

Materiali / Material

Bianco Fenice, Grigio Tunisi, Grigio Billiemi, Bianco di Carrara,
Marmo Nero, Rosso Ducale.

Dimensioni / Dimensions

600x600x20 mm

Peso / Weight

14,6 kg

Design

Fabio Fazio

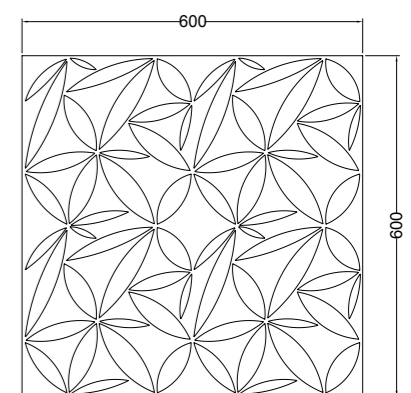

Dune





Materiali / Material

Bianco Fenice, Grigio Tunisi, Grigio Billiemi, Bianco di Carrara, Marmo Nero, Rosso Ducale.

Dimensioni / Dimensions

600x600x20 mm

Peso / Weight

14,6 kg

Design

Fabio Fazio

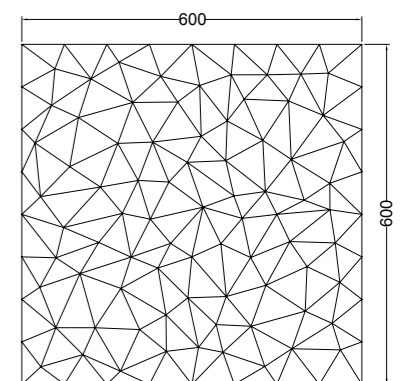

Curve





Materiali / Material

Bianco Fenice, Grigio Tunisi, Grigio Billiemi, Bianco di Carrara, Marmo Nero, Rosso Ducale.

Dimensioni / Dimensions

600x600x20 mm

Peso / Weight

14,6 kg

Design

Fabio Fazio

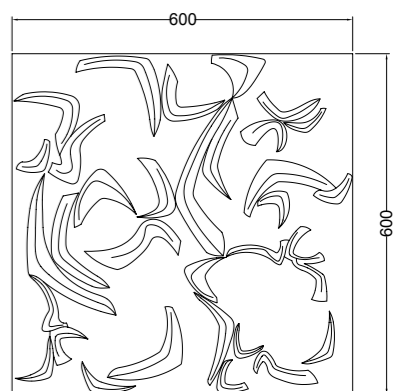

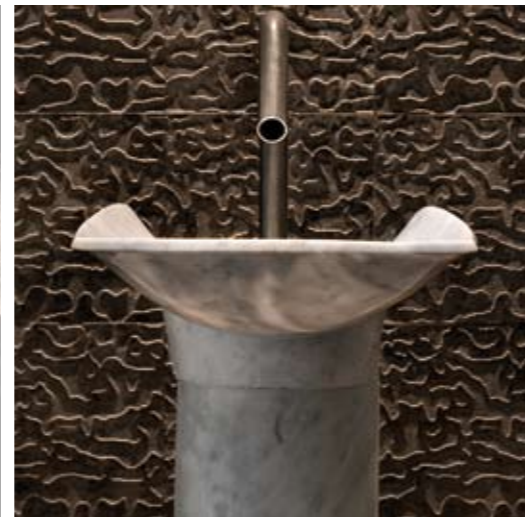

Lavabi

Basins

Ciuri



Materiali / Material
Bianco di Carrara.

Dimensioni / Dimensions
828x417x h 885 mm

Peso / Weight
80,0 kg

Design
Marco Piva

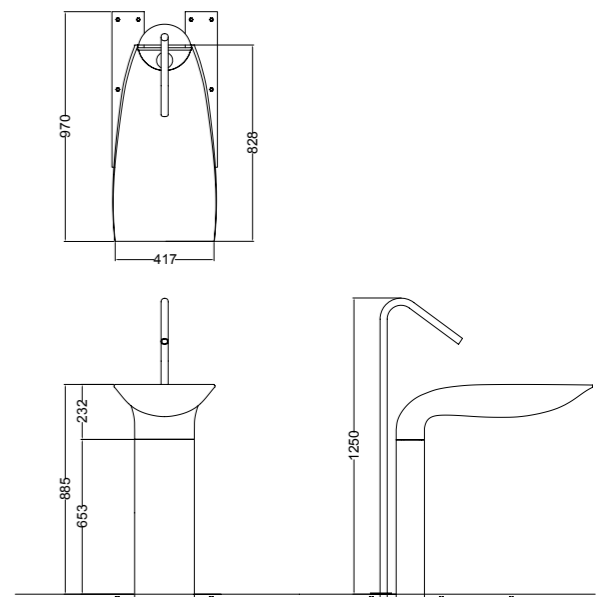

Ciuri

Unna a self standing



Materiali / Material
Bianco di Carrara, Grigio Billiemi.

Dimensioni / Dimensions
663x403x h 800 mm

Peso / Weight
95,0 kg

Design
Marco Piva

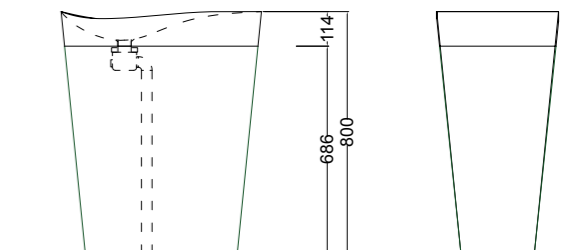
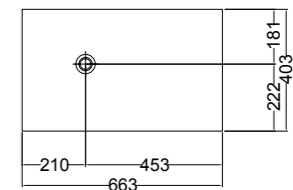

Unna a self standing

Unna b self standing



Materiali / Material
Bianco di Carrara, Grigio Billiemi.

Dimensioni / Dimensions
666x403x h 806 mm

Peso / Weight
80,0 kg

Design
Marco Piva

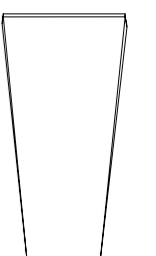
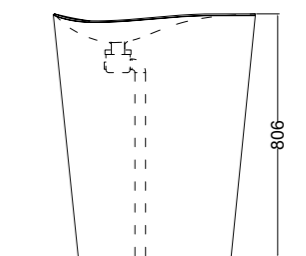
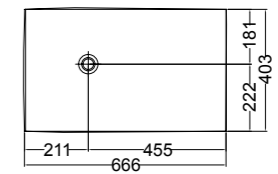

Unna a vanity



Materiali / Material
Bianco di Carrara, Grigio Billiemi.

Dimensioni / Dimensions
663x403x h 114 mm

Peso / Weight
40,0 kg

Design
Marco Piva

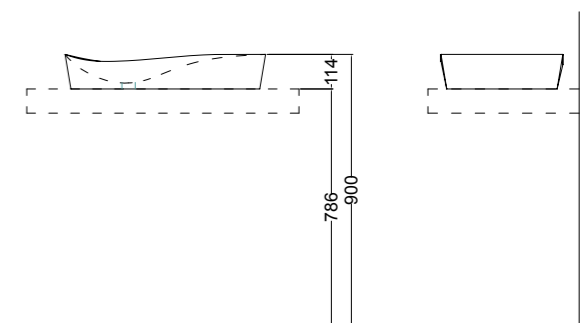
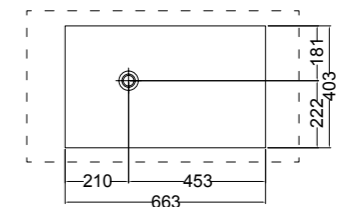

Unna b vanity



Materiali / Material

Bianco di Carrara, Grigio Billiemi.

Dimensioni / Dimensions

666x403x h 122 mm

Peso / Weight

20,0 kg

Design

Marco Piva

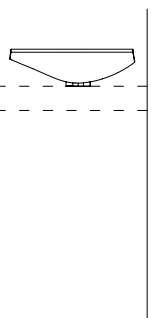
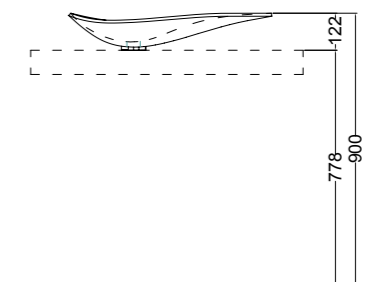
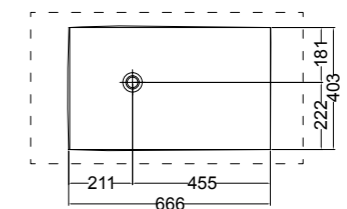

Naca vanity



Materiali / Material
Bianco di Carrara, Grigio Billiemi.

Dimensioni / Dimensions
468x470x h 220 mm

Peso / Weight
40,0 kg

Design
Marco Piva

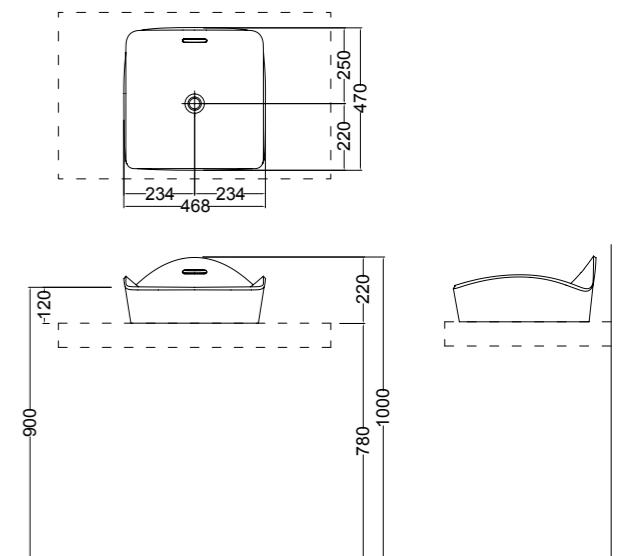

Dune self standing



Materiali / Material
Grigio Tunisi, Grigio Billiemi, Bianco di Carrara, Marmo Nero.

Dimensioni / Dimensions
600x400x h 850 mm

Peso / Weight
80,0 kg

Design
Fabio Fazio

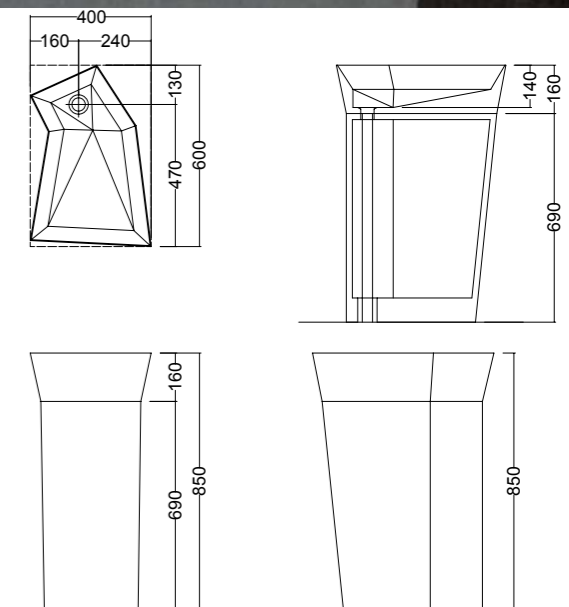

Dune self standing

Dune vanity



Materiali / Material
Grigio Tunisi, Grigio Billiemi, Bianco di Carrara, Marmo Nero.

Dimensioni / Dimensions
600x400x h 160 mm

Peso / Weight
30,0 kg

Design
Fabio Fazio

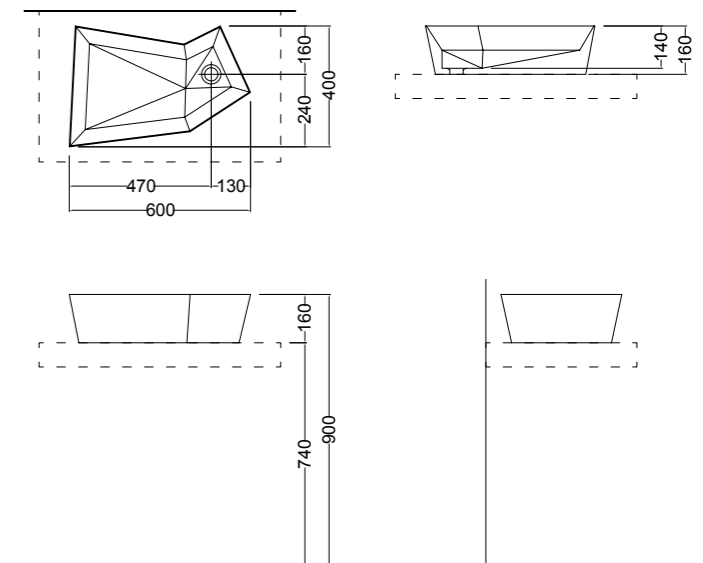

Petali vanity



Materiali / Material

Bianco Fenice, Grigio Tunisi, Grigio Billiemi, Bianco di Carrara, Marmo Nero.

Dimensioni / Dimensions

1200x500x h 130 mm

Peso / Weight

140,0 kg

Design

Fabio Fazio

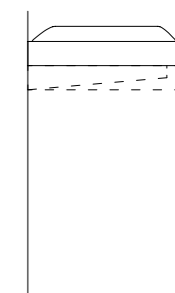
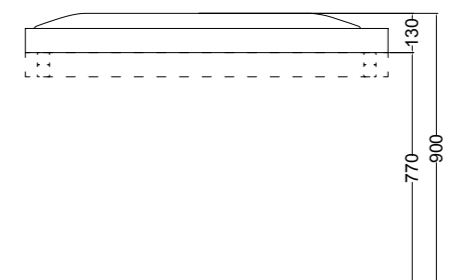
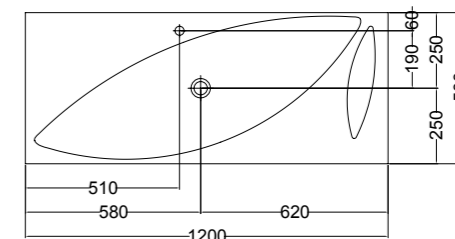

Ciottolo 60/40 a



Materiali / Material

Bianco Fenice, Grigio Tunisi, Grigio Billiemi, Bianco di Carrara, Marmo Nero.

Dimensioni / Dimensions

566x400x h 150 mm

Peso / Weight

35,0 kg

Design

Fabio Fazio

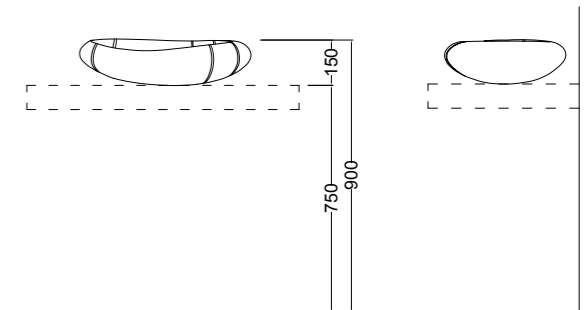
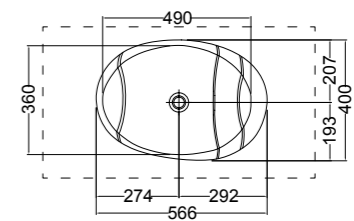

ciottolo 60/40 b



Materiali / Material

Bianco Fenice, Grigio Tunisi, Grigio Billiemi, Bianco di Carrara, Marmo Nero.

Dimensioni / Dimensions

588x400x h 150 mm

Peso / Weight

35,0 kg

Design

Fabio Fazio

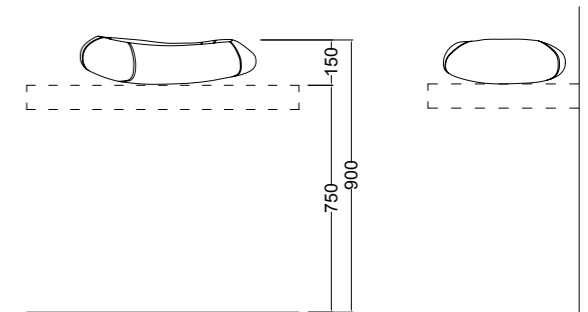
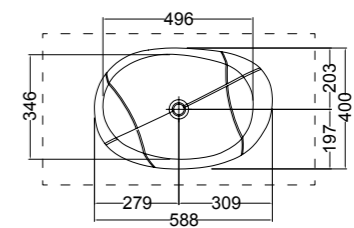

Ciottolo 60/40 b

Curve vanity



Materiali / Material
Bianco Fenice, Grigio Tunisi, Grigio Billiemi, Bianco di Carrara, Marmo Nero.

Dimensioni / Dimensions
540x390x h 110 mm

Peso / Weight
7,0 kg

Design
Fabio Fazio

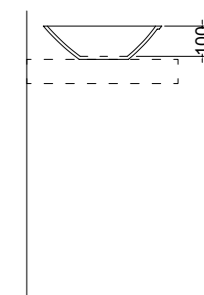
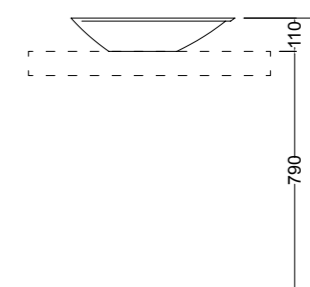
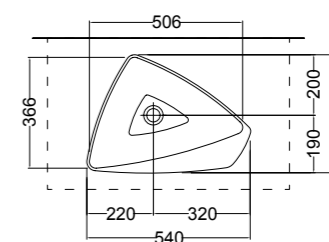



Complementi

Objects

La Torre dei trampolini



Materiali / Material
Pietra Lavica dell'Etna.

Dimensioni / Dimensions
1050x730x h 2600 mm

Peso / Weight
450,0 kg

Design
Michele De Lucchi

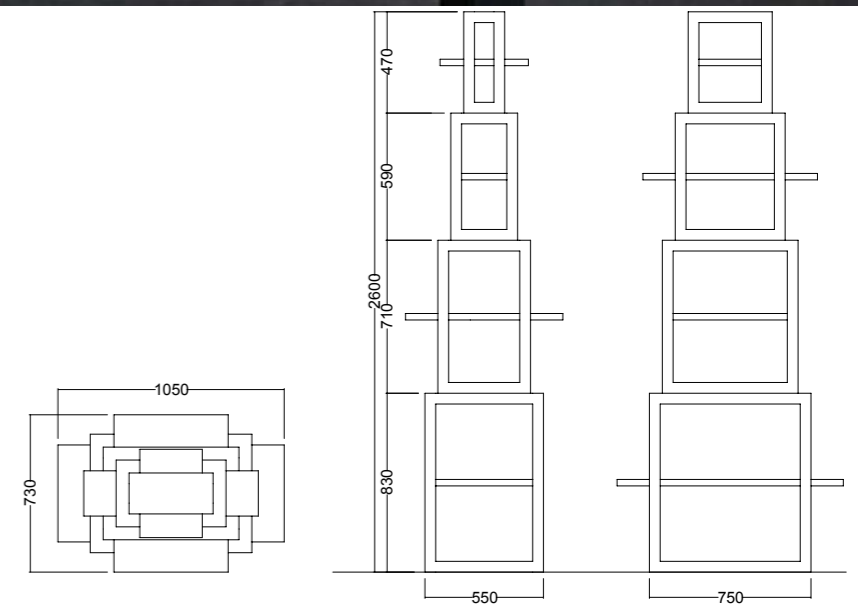

Art Direction

Fabio Fazio
Patrizia Furnari

Graphic Design

Fabio Fazio

Modellazione solida e prototipazione

Domenico Luca

Photo credits

Alberto Parise, pages:

cover,4,5,6,7,8,9,10,11,13,14,17,19,20,21,22,23,24,25,26,31,32.

Enzo Re, pages:

15,16,17,25,26,27,28,29,30.

Alfio Bonina, pages:

12,13,27.

Edition 2011

LITHEA

LITHEA di Patrizia Furnari

Via Case Nuove Russo - Timeto

98066 Patti (ME) - ITALY

tel +39 0941 317708

fax +39 0941 317797

info@lithea.it

www.lithea.it

